

pressure of about 110 atm. The heating element was a graphite cylinder with water-cooled molybdenum electrodes. The applied power was 20 kw. The temperature was measured by a borographite-graphite thermocouple. The thermal insulation of the heating element from the walls of the container was provided by inserts of zirconium dioxide. These authors obtained CdS ingots consisting of several crystallites and in some experiments one monocrystal weighing about 100 g.

From the description given of the apparatus for fusion and crystallization of the CdS it can be seen that it is complex to make and the graphite heated needs too much power.

We have developed a simpler crystallization apparatus whose heating element requires much less energy to achieve the required temperature.

The apparatus is an autoclave containing an electric heating element. The walls of the autoclave are designed to withstand the required pressure at high temperatures and the sealing of the lid of the electrical leads gives a perfect seal during the experiments. A diagram of the apparatus is shown in Fig. 1. A thick-walled cylinder 4 is closed with a lid 2, fastened by eight bolts 3. The lid is sealed by a pressure ring 9 and two chloro-vinyl gaskets 8. Four electric leads 10 enter the cylinder 8, two for the heating element 7 and two for the thermocouple 5. The sealing for the leads makes use of the principle of an "uncompensated area" [6]. In the lid of the cylinder there is a T-piece 1 with a manometer and valve through which the cylinder is filled with gas and then cut off from the gas cylinder. The tube 6 in the bottom of the cylinder is used to blow the cylinder before the experiment. For the thermal insulation of the heating spiral the whole of the internal volume between the walls of the vessel and the reflecting screen is filled with magnesium oxide or aluminum oxide. The whole of the cylinder is placed in a tank with flowing water to give efficient cooling of its walls.

The temperature in the crucible with the CdS melt is measured by a differential platinum-platinum rhodium thermocouple, the "hot" junction of which is at the bottom of the crucible and the "cold" junction at the water-cooled pressure sealing ring. The heating element is a molybdenum wire spiral which surrounds the crucible but is separated from it by corundum rods.

The crucible is made of pure (anodic) graphite and is closed by a graphite lid. The most suitable were crucibles with a thick flat bottom in which a hole was drilled on the outside for a thermocouple fitted with a quartz cover. Before starting the experiments the crucibles were roasted at $\sim 1000^{\circ}\text{C}$, boiled in water for several hours and then dried.

To grow the CdS crystals a pressed powder of cadmium sulphide was put into the graphite crucible. The crucible was placed in the crystallization apparatus and was thermally insulated from the walls, bottom and lid

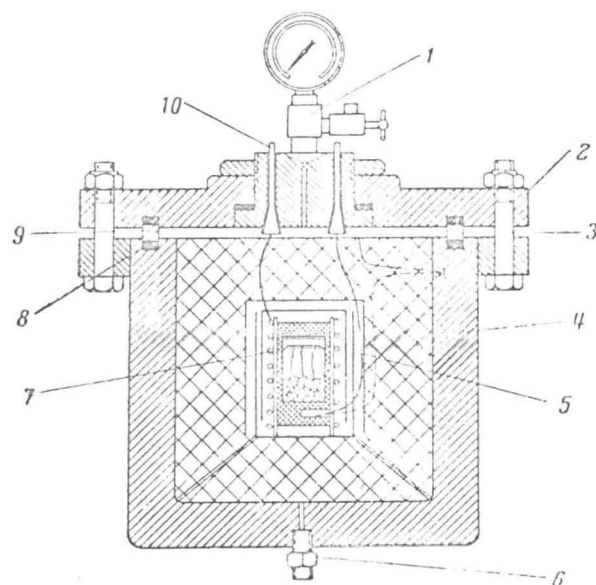

Fig. 1. Diagram of crystallization apparatus.

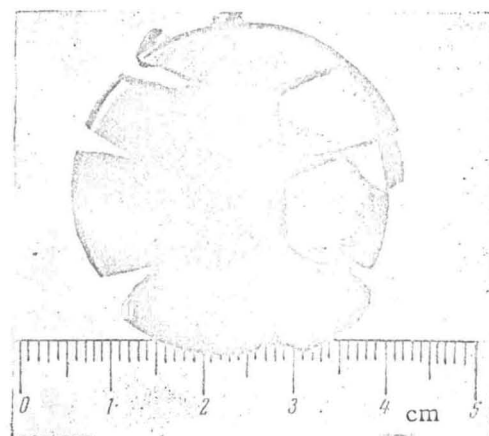

Fig. 2. Monocrystal blocks of CdS.



Fig. 3. Crystal of CdS.